

650nm, High Quality, Standard Model

Application:

Industrial areas

Property:

Wavelength Range = 650nm (others optional)

Introduction:

Egismos created standard and high end laser line generators. Available with many different lenses, electrical characteristics, and with wavelength range from 405nm to IR and many other custom characteristics, Egismos definitely will be able to satisfy any client needs.



Specifications:

Specifications(T=25°C)	Symbol	S936501D/L/C/R S936505D/L/C/R	H936501D/L/C/R H936505D/L/C/R
Mode		CW(TTL)	CW(TTL)
Wavelength	λ	650nm	650nm
Spot		Dot/Line/Cross/Round	Dot/Line/Cross/Round
Diameter x Length	$\Phi \times l$	9x21mm	9x21mm
Output Power	Po	<1mW, <5mW, <10mW <20mW, <50mW	<1mW, <5mW, <10mW <20mW, <50mW
Power Stability		<10%	<5%
Operating Voltage(DC)	Vo	2.6V~6.0V	2.6V~6.0V
CW Operating Current	Io	25~35mA 50mA max	25~35mA 50mA max
Boresight Size	Deg	< 5 degree	1 degree
Divergence Angle	mrad	<1	<0.2, min<0.1
Span Angle		90°+ 5° for Line/Cross	Any angle + 2° for Line/Cross
Operating Temperature	To	-10°C ~+ 50 °C	-10°C ~+ 70 °C or higher max to +90°C
Storage Temperature	Ts	-40 °C ~ + 85 °C	-40 °C ~ + 120 °C
Housing Material		Brass/Aluminum	Brass/Aluminum
Mean time to failure(MTTF)	hrs	4,000~6,000	6,000~8,000

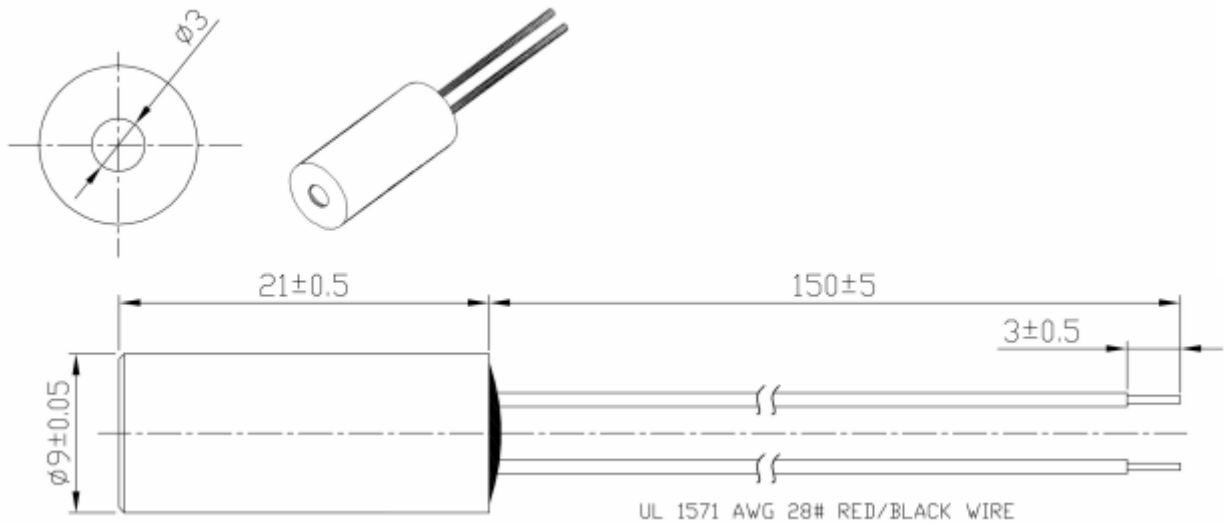
Outline Dimensions:**Certification:****FDA****CE****Laser Safety**

The light emitted from these devices has been set in accordance with IEC60825. However, staring into the beam, whether directly or indirectly, must be avoided.

Class I

The maximum permissible exposure (MPE) cannot be exceeded, it includes High-power lasers within an enclosure that prevents exposure to the radiation and that cannot be opened without shutting down the laser. For example, a continuous laser at 600nm can emit up to 0.39mW, but for shorter wavelengths, the maximum emission is lower.

Class II

"Caution", visible laser light less than 1.0mW. Considered eye safe, normal exposure to this type of beam will not cause permanent damage to the retina.

Class IIIA

"Danger", visible laser light between 1.0mW and 5.0mW. Considered eye safe with caution. Focusing of this light into the eye could cause some damage.

Class IIIB

"Danger", infrared (IR), and high power visible lasers considered dangerous to the retina if exposed. NB: it is important to note that while complying with the above classifications, unless otherwise stated. Our laser diode products are not certified and are designed solely for use in OEM products. The way in which device is used in the final product may alter its original design classification, and it is the responsibility of the OEM to ensure compliance with the relevant standards.